

cargo

Nomad and Flatbed™

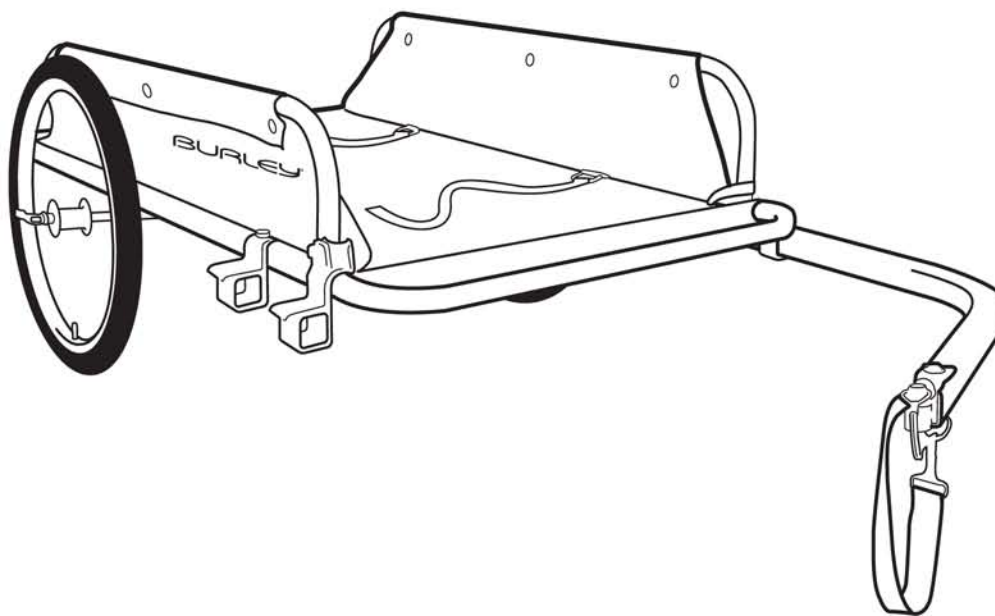
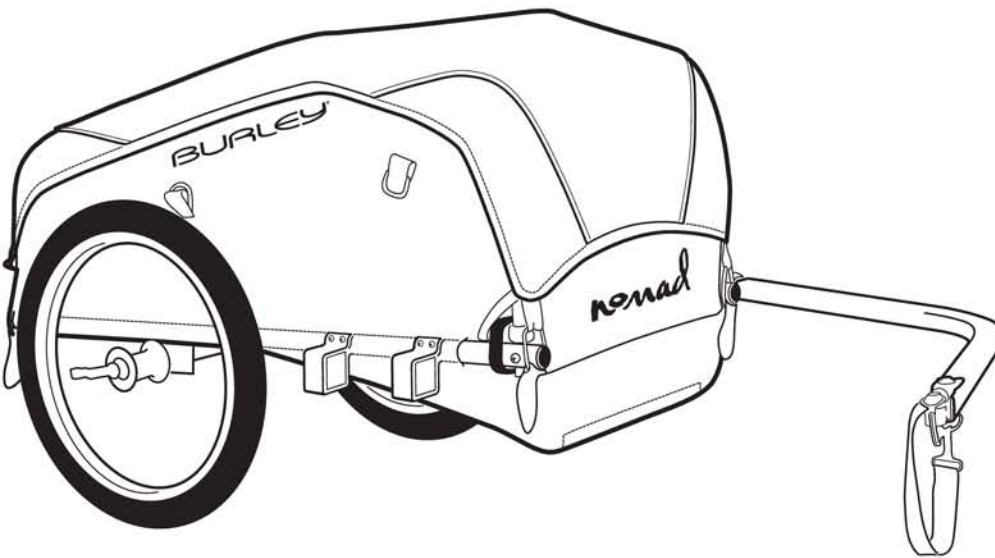
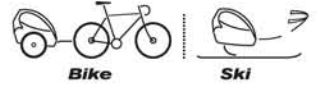

Owner's Instruction and Safety Manual

Burley Nomad and Flatbed™

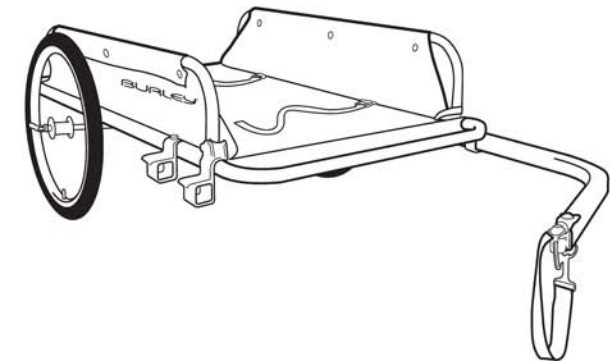
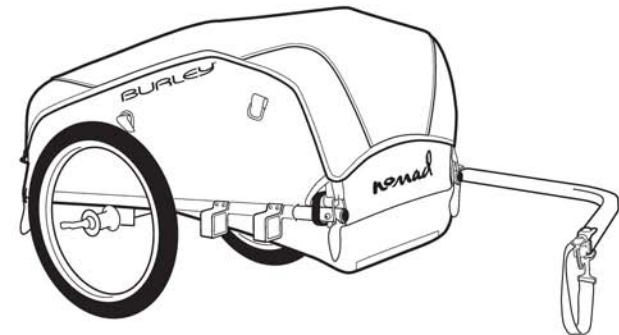

Contents

- 3** Introduction
- 3** Safety Guidelines
- 3** Tool List
- 4** Mounting the Light
- 4** Attaching Wheels
- 4** Installing Side Rails
- 5** Mounting Reflectors
- 6** Installing Tailgate and Splashguard
- 6** Installing Roll Bar and Cover
- 6** Installing Tow Bar
- 7** Installing Safety Flag (Nomad Only)
- 7** Hitching Trailer to Your Bicycle
- 8** Safety Checklist
- 8** Maintenance and Storage
- 9** Nomad Replacement Parts and Diagram
- 10** Flatbed Replacement Parts and Diagram
- 12** Warranty

Congratulations!

Your Burley® trailer is the leading choice of refined bicycle trailer owners worldwide. Every effort has been made to ensure your purchase is of top quality and proven design, ready to provide you with many years and miles of happy, safe trailering.

IMPORTANT

IT IS VERY IMPORTANT FOR YOU TO FAMILIARIZE YOURSELF WITH YOUR BURLEY BY READING THIS ENTIRE MANUAL BEFORE USE. IF YOU HAVE ANY QUESTIONS, PLEASE CONTACT YOUR AUTHORIZED BURLEY DEALER.

Introduction

Once you've done the initial assembly and read the safety guidelines, you're ready to go! Before trailering, be sure you have the tow bar, trailer wheels and hitch securely attached.

NOTE: Any reference to left or right is made in direction of travel, as if you were standing behind the trailer, looking forward.

Safety Guidelines

WARNING

BICYCLING WITH A TRAILER, AND BICYCLING IN GENERAL, CAN BE HAZARDOUS. FAILURE TO OBSERVE ANY OF THE SAFETY GUIDELINES IN THIS MANUAL COULD RESULT IN AN ACCIDENT AND SERIOUS INJURY OR DEATH.

1. Inspect and maintain your bicycle and trailer regularly. See "Safety Checklists".
2. Because of the trailer's additional weight, a bicycle pulling a trailer is heavier and less responsive. Avoid sudden swerving, rocks and curbs. Experiment with the loaded trailer in an uncongested area until you become familiar with it.
3. The total weight limit for the trailer and cargo is 100 lbs (40 kg in Europe). Load cargo securely in the center, forward of the axle and as low as possible.
4. Observe recommended speed limits: a maximum of 15 mph (24 km/h) on smooth, straight roads and 5 mph (8 km/h) or less when turning or on uneven roads.
5. Never pull your trailer with a motorized vehicle.
6. The cyclist must wear a helmet.

7. Only use factory-supplied wheels, with the tires inflated to the pressure recommended on the tire side wall. Check pressure before each use.
8. Clamp the hitch securely to the bicycle frame, and check for a tight attachment before each use.
9. Use the safety flag. (Nomad Only)
10. Do not make alterations to the trailer. Contact your Authorized Burley Dealer or go to www.burley.com for replacement of any damaged, worn-out or missing parts.
11. Do not use your trailer on icy roads or when inclement weather makes cycling hazardous.
12. The use of a mirror on your bicycle is recommended.
13. For emergencies, breakdowns or flat tires, pull completely off the road and move to a safe area before doing repairs.

Parts Bag Contents:

NOMAD: (1) Red light with bracket
(2) Roll bar knobs
(1) Hitch
(1) Burley Owner's Instruction and Safety Manual

FLATBED: (4) Retaining pins
(2) Pair tie-down straps
(2) Clear reflectors with brackets/screws
(2) Red reflectors with brackets/screws
(1) Hitch
(1) Burley Owner's Instruction and Safety Manual

Tools Required: Phillips Screwdriver

! WARNING

TRAILERS CAN TIP OVER, CAUSING DAMAGE TO TRAILER AND SERIOUS INJURY TO CYCLIST. AVOID CAUSES OF TIP OVER, ESPECIALLY:

- HITTING POTHOLES, CURBS, OTHER ROAD OBSTRUCTIONS
- TAKING TURNS TOO FAST
- SUDDEN SWERVING
- IMPROPER WHEEL INSTALLATION OR TIRE INFLATION

Mounting the Light

NOMAD:

1. Insert batteries into light.
2. Screw light and bracket together.
3. Mount light/bracket horizontally on rear corner of main frame tube, on side closest to traffic. **PHOTO 1**

Attaching Wheels

1. Insert wheel axle assembly completely into trailer axle. **FIGURE 1**
2. Close quick release lever, with lever aimed at trailer rear. A properly adjusted quick release lever should leave an imprint on your palm when the lever is rotated to the closed position. **FIGURE 2**
3. Verify that tires are inflated to pressure marked on tire side wall.
4. To remove wheel from trailer axle, open quick release lever.

! WARNING

MAKE SURE WHEELS ARE HELD SECURELY, WITH WHEEL SHAFT FULLY INSERTED INTO HOLLOW AXLE. YOU SHOULD NOT BE ABLE TO ROCK OR SHIFT WHEELS. IMPROPERLY INSTALLED WHEELS CAN FALL OFF, CAUSING AN ACCIDENT OR SERIOUS INJURY.

Installing Side Rails

Nomad:

1. On trailer sides, flip the four C-shaped side panel hold-downs to outside of trailer frame. **PHOTO 2**
2. Slide vertical side rails down over side rail guides on trailer sides, with narrower end of side panels to the rear and "Burley" logo facing outward. **PHOTOS 2 & 4**
3. Snap all four side panel hold-downs over side panel tubing. **PHOTO 3**

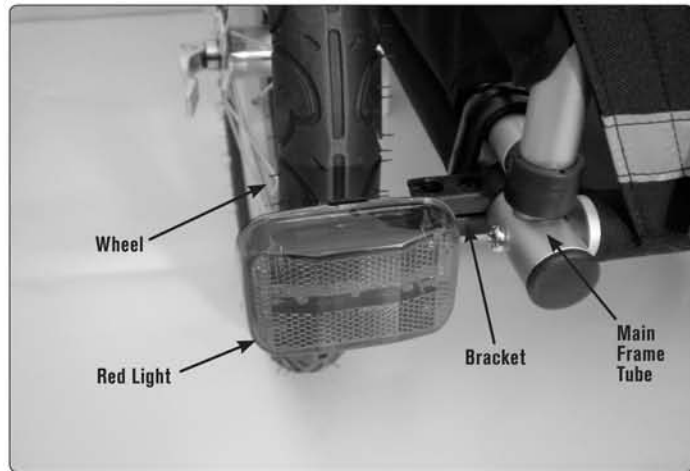

PHOTO 1: Nomad light/bracket mounted on rear corner of main frame tube

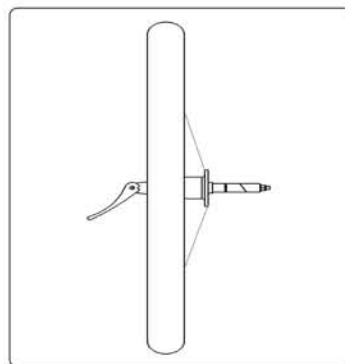

FIGURE 1: Quick release lever in unlocked "open" position (Top View)

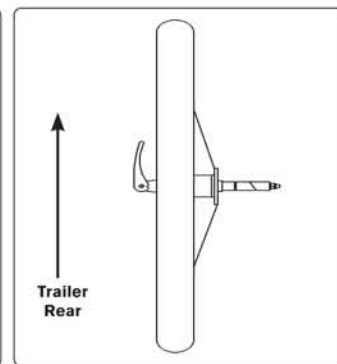

FIGURE 2: Quick release lever in locked "closed" position (Top View)

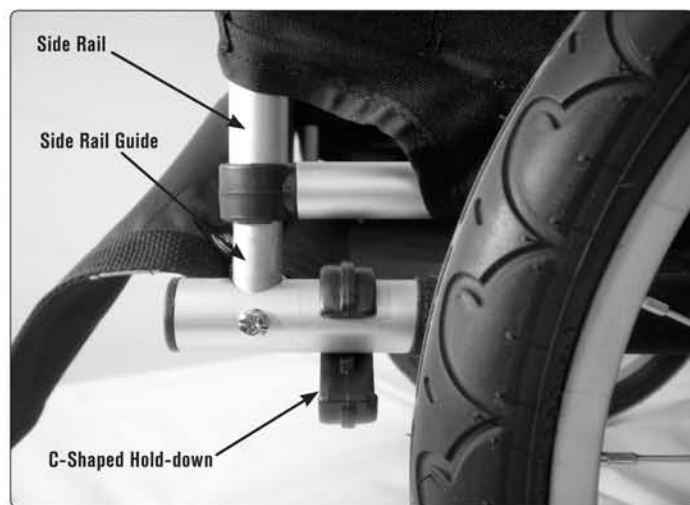

PHOTO 2



PHOTO 3: Hold-down locked over side panel tubing

WARNING

IF ALL HOLD-DOWNS ARE NOT SNAPPED IN PLACE BEFORE USING THE TRAILER, THE SIDE RAILS CAN SHIFT OR COLLAPSE, RESULTING IN THE LOSS OF CARGO.

Flatbed:

1. Slide ends of side panel rail into front and rear receivers on side of frame, matching holes in plastic tubing ends with holes in receivers. **PHOTO 5**
2. Insert retaining pins through holes on all four corners, and lock retaining hoops securely. **PHOTO 5**

Mounting Reflectors

Flatbed:

1. Screw reflectors and brackets together.
2. Mount clear reflectors/brackets horizontally on front corners of side panel rail tubes. **PHOTO 6**
3. Mount red reflectors/brackets horizontally on rear corners of side panel rail tubes. **PHOTO 7**



PHOTO 4: NOMAD SIDE PANEL ORIENTATION

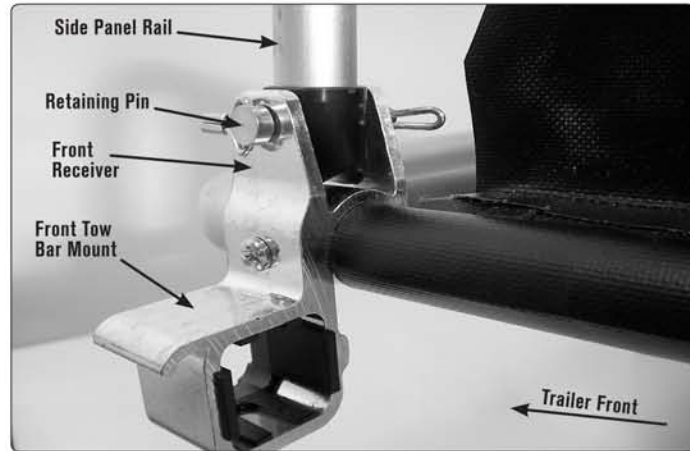

PHOTO 5: FLATBED SIDE PANEL ATTACHMENT

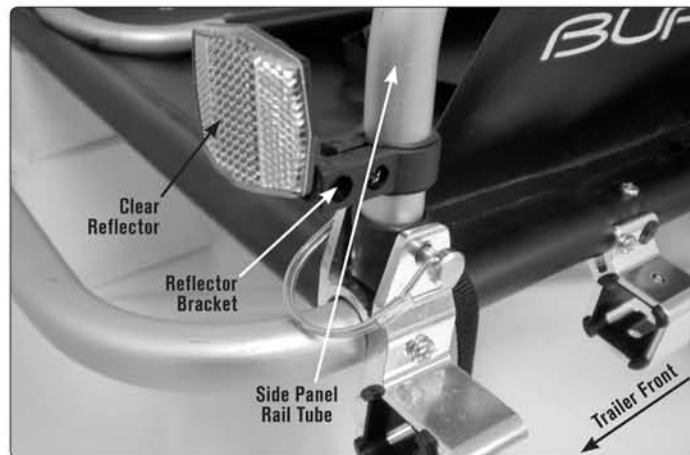

PHOTO 6: FLATBED CLEAR REFLECTOR/BRACKET MOUNTED ON FRONT CORNER OF SIDE PANEL RAIL TUBE

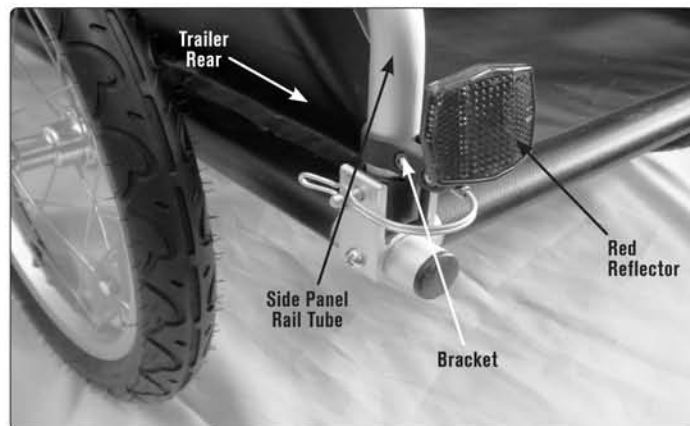

PHOTO 7: FLATBED RED REFLECTOR/BRACKET MOUNTED ON REAR CORNER OF SIDE PANEL RAIL TUBE

Installing Tailgate and Splashguard

Nomad:

1. Loop tie-down straps over corners of side panels and join male buckle sections on straps to female buckle sections inside trailer. **FIGURE 3 & PHOTO 8**
2. To accommodate different sizes of cargo, tighten or loosen the webbing straps as needed. **PHOTO 8**

Installing Roll Bar and Cover

Nomad:

1. Place cover over side panels, with "Nomad" logo at trailer front. **FIGURE 3**
2. Slip one roll bar knob through a grommet on cover. **FIGURE 3**
3. Slide roll bar through casing in divider, and match roll bar end with its corresponding hole on side rail. **FIGURE 3**
4. Thread roll bar knob through side rail, and tighten.
5. Repeat for knob on other side.
6. Loop O-rings on cover over trailer frame tube ends. Make sure cover extends over top of side panels.

Installing Tow Bar

1. Slide tow bar through both tow bar mounts on left side.
2. Match rear tow bar hole with rear mount hole.
3. Insert the retaining pin through both holes, and lock retaining hoop securely. **PHOTO 9 & PHOTO 10**

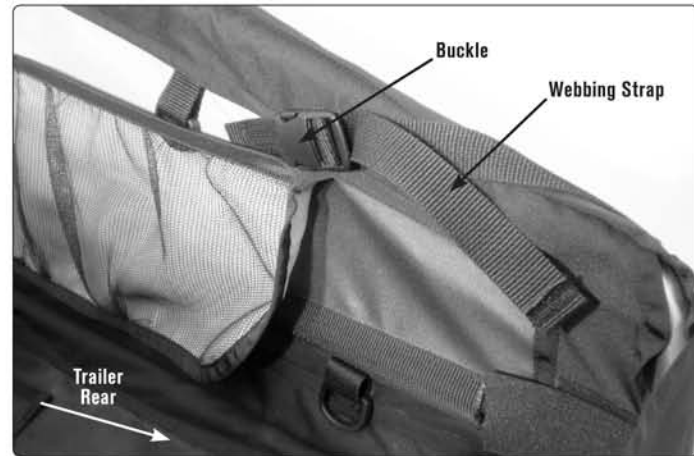

PHOTO 8

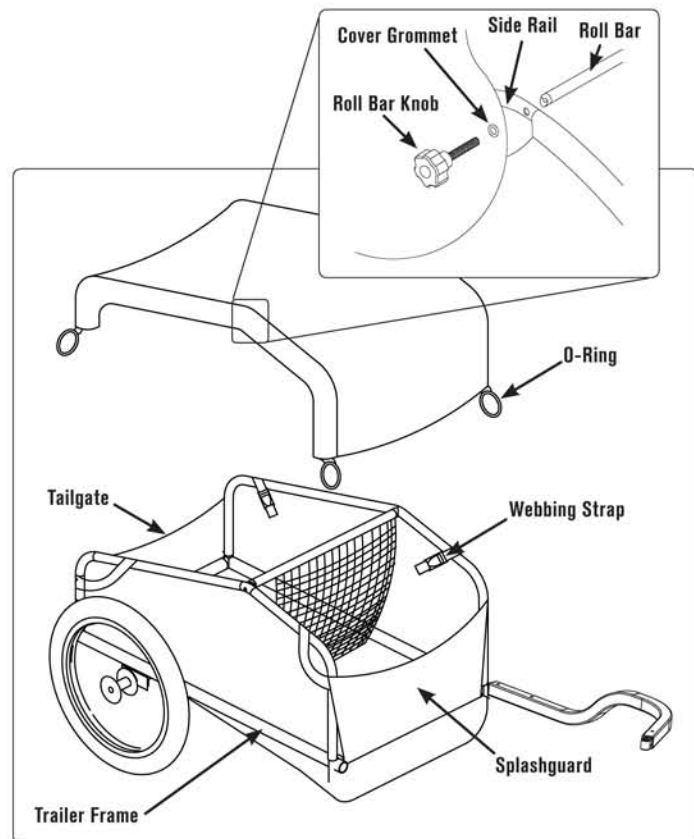

FIGURE 3: NOMAD

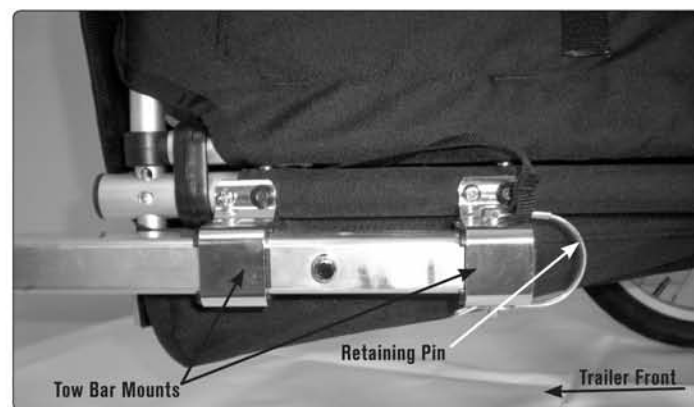

PHOTO 9: NOMAD TOW BAR INSTALLATION

⚠️ WARNING

NEVER OPERATE TRAILER WITHOUT RETAINING PIN LOCKED IN PLACE. AN UNLOCKED TOW BAR CAN LOOSEN OR DETACH, CAUSING ACCIDENT RESULTING IN SERIOUS INJURY.

Installing Safety Flag

Nomad:

Join flag pole sections together and insert end into flag pocket on inside of left side panel.

⚠️ WARNING

DO NOT USE TRAILER WITHOUT SAFETY FLAG.

Hitching Trailer to Your Bicycle

1. Remove rear quick release lever assembly from bike.
2. Match hole on flat side of hitch upper arm to left (non-chain ring side) rear dropout hole.
3. Loosely reassemble quick release assembly through hitch, dropout and wheel. **FIGURE 4**
4. Slide flex connector between hitch side arms, and match holes. Racks, bags, or fittings should not interfere with hitch.
5. Open retaining pin and insert through hitch and flex connector holes. Rotate and close retaining hoop.
6. Tighten and close quick release lever, with lever pointing to rear of bike. A properly adjusted quick release lever should leave an imprint on your palm when the lever is rotated to the closed position.
7. Wrap safety strap twice around inside of chain stay. Fasten hook to D-ring on underside of tow bar end. **FIGURE 5**
8. To remove trailer from bicycle, unfasten clip from D-ring and remove retaining pin.

⚠️ WARNING

QUICK RELEASE LEVER MUST BE IN CLOSED POSITION AND HITCH SAFETY STRAP PROPERLY INSTALLED. HITCH MUST NOT INTERFERE WITH RACKS, BAGS OR FITTINGS. INSPECT HITCH AND TOW BAR FREQUENTLY FOR DAMAGE OR LOOSE FASTENERS. DAMAGED, IMPROPERLY INSTALLED OR INTERFERING PARTS CAN CAUSE ACCIDENTS RESULTING IN SERIOUS INJURY.

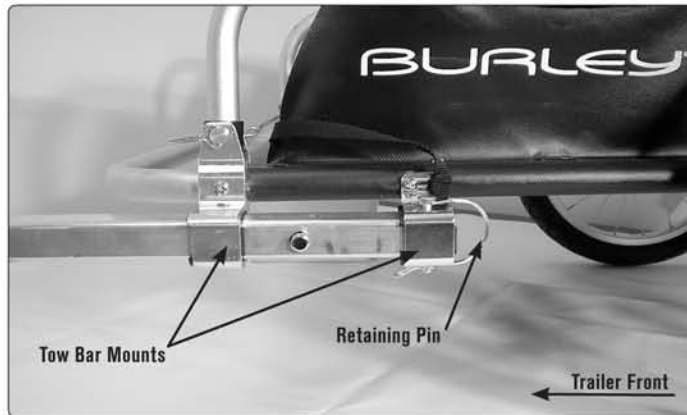

PHOTO 10: FLATBED TOW BAR INSTALLATION

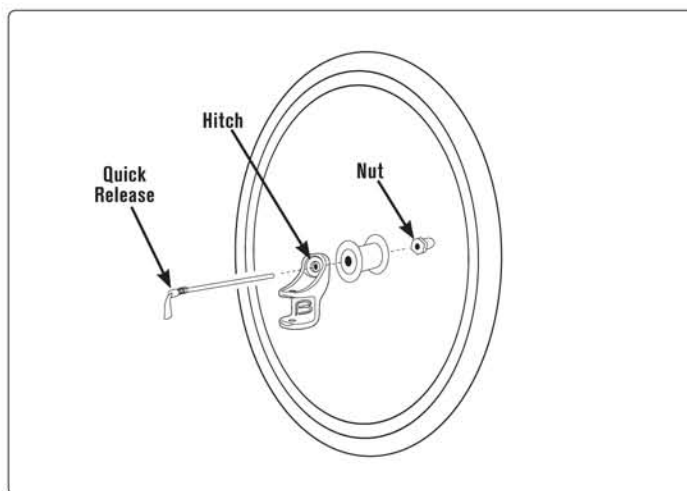

FIGURE 4

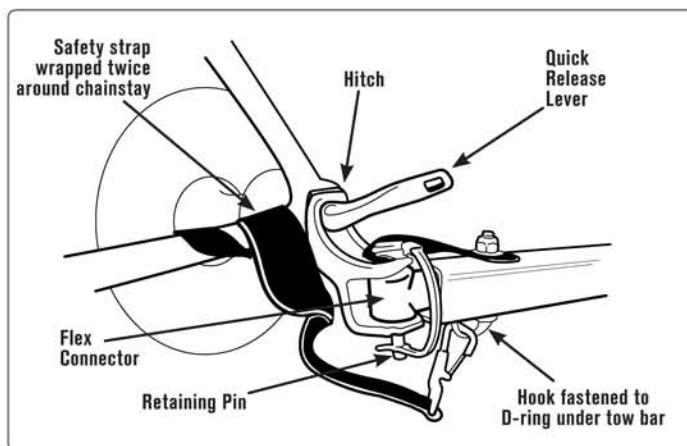

FIGURE 5

Safety Checklists

Check Before Each Ride:

- ✓ Wheels tightly attached, with quick release levers securely locked
- ✓ Tires inflated to recommended pressure on tire side wall
- ✓ Hitch properly secured with safety strap in place
- ✓ Locked retaining pin for tow bar
- ✓ Maximum load 100 lbs (40 kg in Europe)
- ✓ Bicycle safety check, especially brakes and tires
- ✓ Helmet for cyclist
- ✓ Safety flag in place (Nomad Only)
- ✓ Cargo loaded and secured correctly

Monthly Checklist

- ✓ Inspect tow bar, hitch, frame tubing, flex connector and hardware for damage
- ✓ Inspect tires for wear and cracks
- ✓ Inspect wheels for trueness and cracks
- ✓ Inspect wheel bearings for wear
- ✓ Inspect fabric parts for rips, abrasion, or missing or damaged hardware
- ✓ Contact your Authorized Burley Dealer for replacement of any damaged or worn-out parts

Maintenance and Storage

Hitch and Tow Bar Maintenance

Store trailer indoors if possible. Do not use or store trailer at temperatures below 32°F (0°C), as the hitch flex connector can become brittle and possibly break, causing an accident resulting in serious injury.

Fabric Care

Hand wash fabric parts with mild soap or detergent and warm water. For heavy soiling, use a nylon bristle brush. Do not use bleach. Polyester fabric will eventually fade, especially when exposed to direct sunlight. Wipe dry (to help avoid mildew) and store out of direct sunlight in a dry, well ventilated area, or use a Burley Trailer Storage Cover to protect your trailer. Replace any damaged parts.

2009 Nomad Replacement Parts and Diagram

Diagram #	Part #	Description	Warranty
1	960041	Forged Standard Hitch	lifetime
2	960009	Safety Flag	1 year
3	4325401	Tonneau Cover	1 year
4	4326502	Bag	1 year
5	950022	Left Side Panel on Frame	1 year
6	950023	Right Side Panel on Frame	1 year
7	250122	Tow Bar Assembly	lifetime
8	160021	Wheel (SOLD INDIVIDUALLY)	5 years
9	950019	Tow Arm Guide Kit	5 years
10	950026	Side Rail Posts (set of 2)	lifetime
11	950027	Snap Coupling Kit (Set of 4)	5 years
12	4310007M	Rollbar with Knobs	lifetime
13	950072	Nomad Frame Kit	lifetime
14	950029	Axle Tube Assembly	lifetime
15	950038	Flex Connector for Square Tow Bar w/ Safety Strap	5 years

Please go to www.burleygear.com for updated product parts list and diagrams

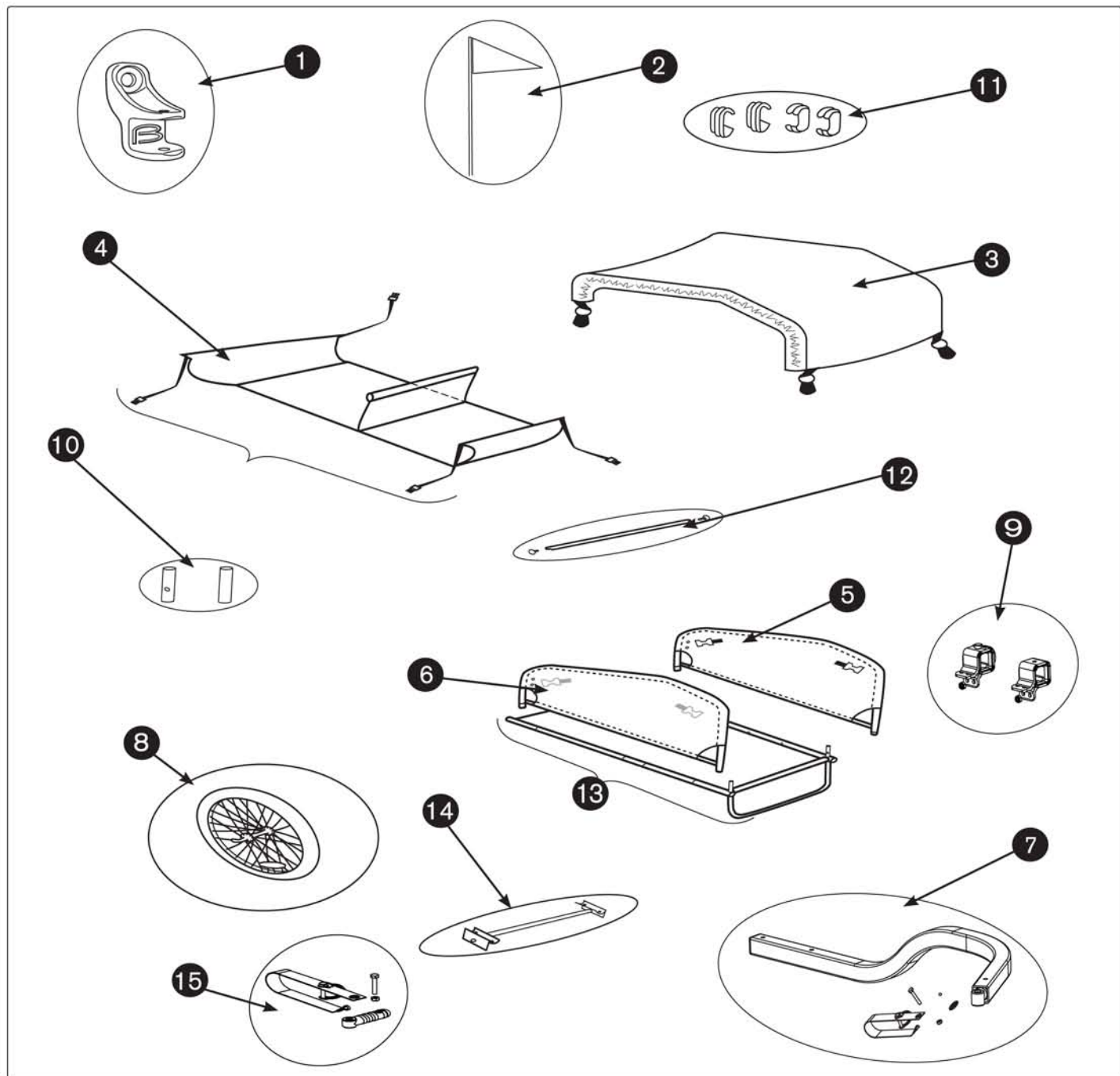

2009 Flatbed Replacement Parts and Diagram

Diagram #	Part #	Description	Warranty
1	960041	Forged Standard Hitch	lifetime
	950096	Fabric Floor (NOT SHOWN)	1 year
2	250122	Tow Bar Assembly for Square Tow Bar	lifetime
3	160021	Wheel (SOLD INDIVIDUALLY)	5 years
	950005	Tow Bar Receiver Kit (NOT SHOWN)	5 years
4	950073	Side Rails (set of 2)	lifetime
5	4130010	Hold Down Straps (set of 2)	1 year
6	950074	Flatbed Frame Kit	lifetime
7	950097	Axle Assembly	lifetime
8	950038	Flex Connector for Square Tow Bar w/ Safety Strap	5 years

Please go to www.burleygear.com for updated product parts list and diagrams

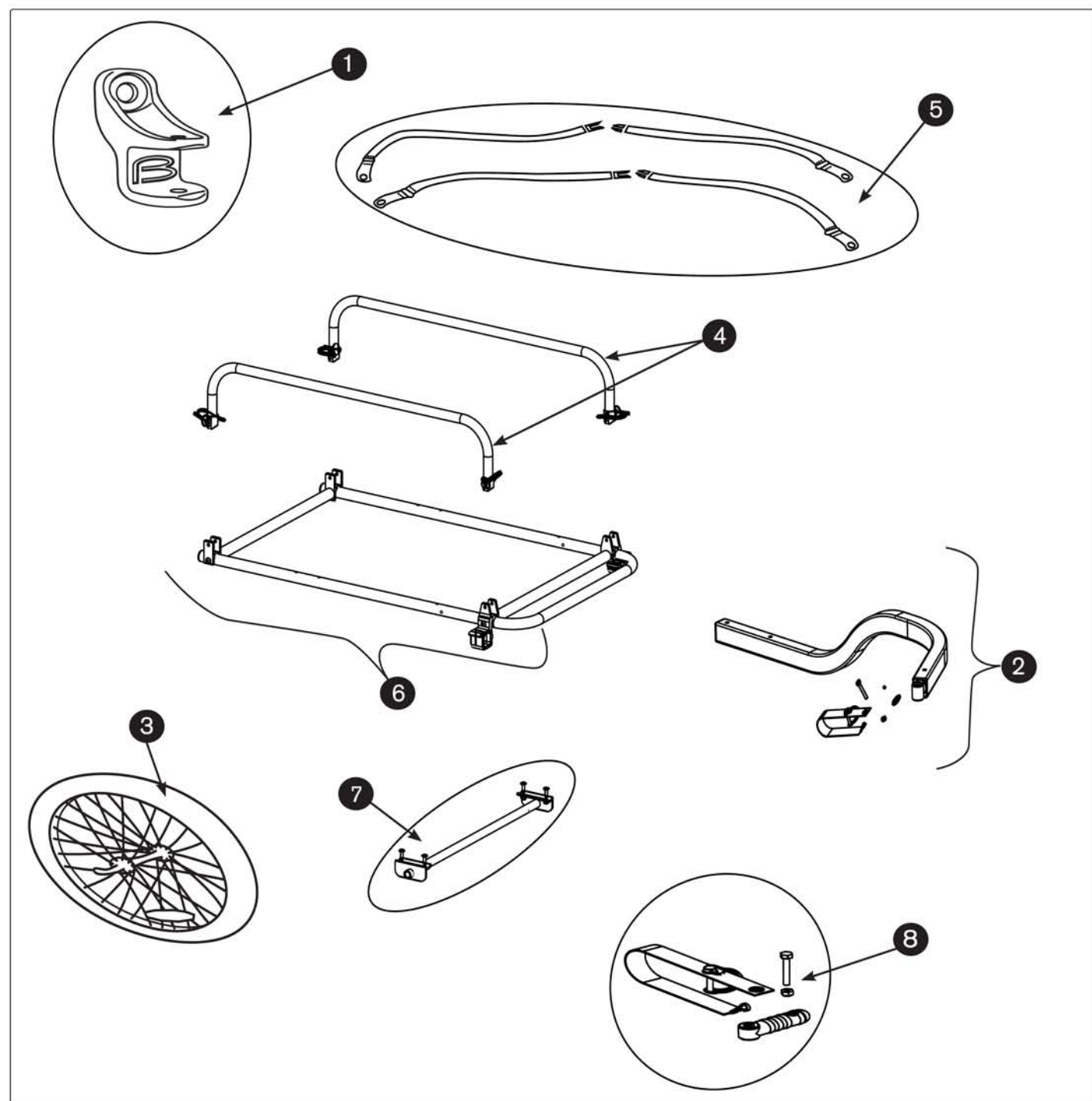

Notes:

Burley Trailer Limited Warranty

Burley trailers are warranted from date of purchase against defects in materials and workmanship under normal use and service. Burley will repair or replace parts it determines to be defective as follows: fabric parts for one year, plastic parts for five years and durable frame parts for the lifetime of the trailer. The Burley trailer owner must present the trailer for repair at place of purchase, with an original sales receipt or similar proof of purchase. This warranty applies only to the original owner and is nontransferable. Burley can not be responsible for failure due to improper assembly, modification of parts or instructions, neglect, abuse, accident, and/or normal wear. The warranty does not cover any trailer used for rental, competition, or commercial use.

Burley neither assumes nor authorizes any person to assume any other liability in connection with this Burley product, and there are no oral agreements or warranties collateral to or affecting this agreement. This warranty gives you specific rights. You may also have other rights which vary by state or country.

BURLEY®